

F45-M100 LINEAR ACTUATORS

UP TO **78 kN** **Tr** **KGS BALLS**

The capacities indicated correspond to the standard input shaft configurations. Higher capacities are available on request.

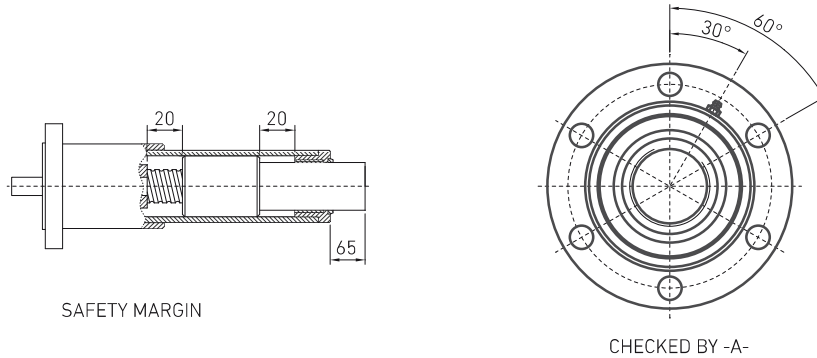
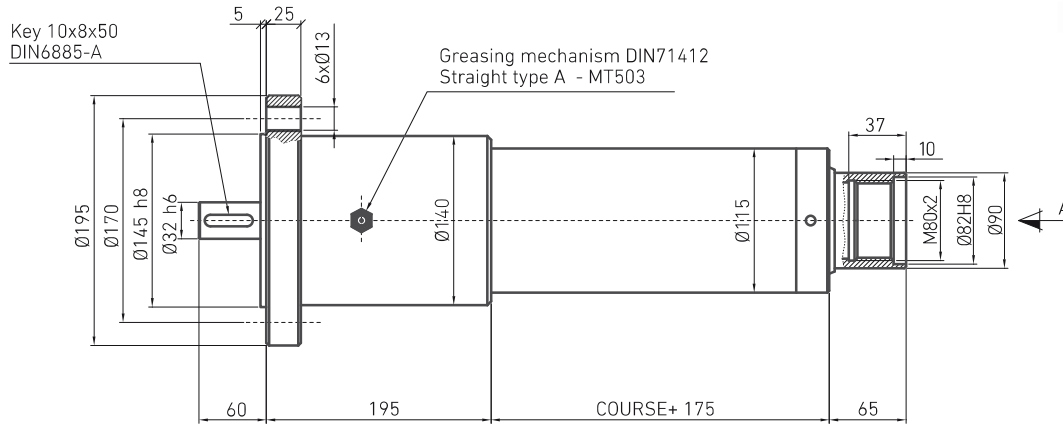

Screw diameter and step (mm)	Maximum axial strength (kN)	Travel (mm/ revol. input)	Performance (%)	Drive torque, M_D (Nm) F (kN), load to move in dynamic	Stroke weight Q (kg)	Approx. weight each 100 mm of Stroke (kg)
Tr 50x8	47.5	8	30	$(4.24 \times F) + 2.1$	28.3	5.2
KGS 5010	78	10	81	$(1.96 \times F) + 1.7$	28.3	5.2

... Power required: P_D (kW) = $0,157 \times M_D$ (Nm).

... Contact NIASA if the dynamic load exceeds the critical values indicated, in order to avoid over-heating, buckling and resonance of the unit. See calculations chapter at the end of the chapter (page 97).

