

ES LINEAR ACTUATOR F/A - CONFIGURATION M605

UP TO

86 kN



In line motor

There is a large range of reductions available for the M605 configuration.

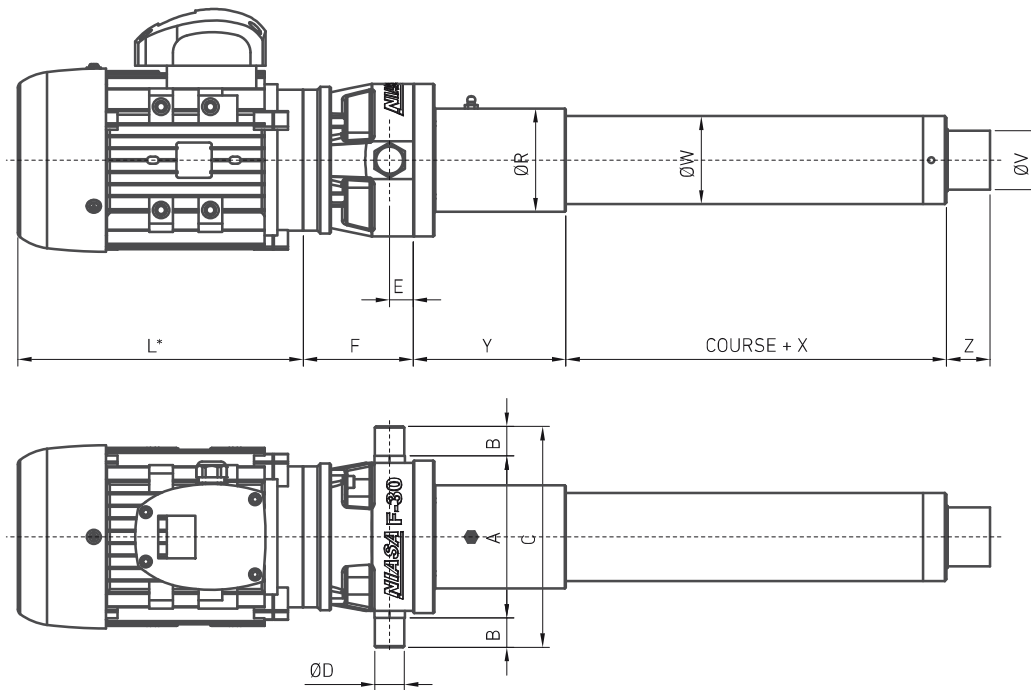

*Depends on the motor group selected and the manufacturer.
For further information, please contact the NIASA technical department

	M205 configuration dimensions					M100 configuration general dimensions						
	A	B	C	ØD f8	E	X	Y	Z	ØV	ØW	ØR	More dimensions
F16	82	15	112	15	12	84	61	36	32	40	45	Page 78
F20	116	20	156	20	15	106	100	36	35	55	66	Page 80
F30	138	25	188	25	20	124	130	37	50	75	88	Page 82
F40	160	40	240	35	30	155	150	67	70	90	110	Page 84
F45	200	40	280	40	35	175	195	65	90	115	140	Page 86
F50	260	50	360	45	40	185	300	95	110	150	196	Page 87